

ACTIVITY REPORT
2013





CONTENTS

3 PROFILE

- 4 Interview
- 6 Coordination Committee
- 8 Key figures
- 10 Locations

12 EXCELLENCE

- 14 Safety
- 16 Quality, environment
- 18 Expansion
- 20 Client focus
- 22 New solutions
- 24 Talents

26 ACTIVITY

- 28 Soils
 - 30 Soletanche Bachy
 - 34 Menard
- 38 Structures
 - 40 Terre Armée
 - 44 Freyssinet
- 48 Nuclear
 - 50 Nuvia France
 - 52 Nuvia Limited, Envinet

P R O F I L E

As the world leader in soil, structural and nuclear engineering, the Soletanche Freyssinet Group brings together an unparalleled array of specialised civil engineering capabilities.

3 BUSINESS SEGMENTS
5 BRANDS

SOILS



STRUCTURES



NUCLEAR



Operating in some 100 countries, its 20,000 employees meet the needs of clients by devising and implementing solutions tailored to the specific features of each project, whatever its complexity and scale.

Working on thousands of projects every year, they help design, build, maintain and repair a wide variety of structures. Their expertise, combined with a culture of technical excellence and strong technological creativity, help boost the performance and durability of each structure.

What is your overall impression of 2013?

The Soletanche Freyssinet Group recorded an increase in revenue compared to 2012, confirming its strength. We also won a number of orders for significant new projects, such as the contract awarded to Freyssinet to design and build the stay cables on the third Bosphorus Bridge.

The Bosphorus Bridge is a good illustration of the technical and human challenges that we enjoy tackling and that constitute our core business. Other good examples include the two bridges in Vladivostok, Russia, and the Wolf Creek Dam in the United States. Each is an iconic, once-in-a-decade project! We take collective pride in having been able to showcase French engineering talent in the world with these projects.

In 2013, we also set up the SoilTeam, celebrated the 50th anniversary of Reinforced Earth®, launched the NuviaTech Instruments range and introduced an Excellence plan.

The SoilTeam consolidates the Group's leadership in geotechnical engineering. It puts the complementary expertise of Soletanche Bachy and Menard together to form a comprehensive range of products and services. The capabilities of the SoilTeam span across all types of projects, from small local geotechnical works to specialised works such as ground improvement, tunnel boring, marine works, monitoring, remediation, and integrated project management.

A half-century after it was founded, Terre Armée continues to build on its dynamic technique to diversify into hydraulic engineering, port, industrial and mining facility and environmental protection projects. Terre Armée completed its largest-ever project, the North Tarrant Express in the U.S.

state of Texas, where the use of Reinforced Earth® as a replacement technique in bridge building generated substantial savings for the client.

In nuclear engineering, the seamless integration of the Czech Republic-based Envinet company enabled Nuvia to broaden its range of products and services and launch a comprehensive range of nuclear measurement equipment, NuviaTech Instruments. This initiative is part of our endeavour to deliver increasingly reliable, precise and integrated solutions in the fields of services, risk control, engineering and design-build projects.

2013 was the year of excellence. What goal underpins the Excellence⁶ plan?

As the world leader in specialised civil engineering, we have a duty to provide our clients with technical and human excellence in each of our business lines. It is crucially important, as we see it, to offer the highest possible level of service on our worksites. We have the ability to propose the most suitable solutions at all phases of the project, from design to execution.

Because excellence must be our hallmark and because it must underpin every aspect of the way we conduct our business, we initiated a powerful, unifying and ambitious plan in 2013 that positions our five companies in growth markets. The goal is to accelerate our expansion, at the required level of excellence, by focusing on six areas in which we can achieve continuous improvement. This means combining discipline and creativity to deliver excellence in each of our clients' projects.

I N T E R V I E W



The Vladivostok bridges and the Wolf Creek Dam are iconic, once-in-a-decade projects! We take collective pride in having been able to showcase French engineering talent in the world with these projects.



Jérôme STUBLER
Chief Executive Officer,
Soletanche Freyssinet

What are your priorities in 2014 and what is the outlook for expansion?

Keeping our people safe is our first priority. In all the countries where we operate and on all our projects, we strive to instil a strong safety culture at each phase of the project – design, methods, works and equipment. Our managers and employees are constantly focused on one objective: zero accidents.

Continuing the local and global expansion of our networks. Our companies have substantial scope for growth by extending their local roots, gaining an increasing foothold in high-growth regions (South and Central America, North

America and Asia) and accelerating our expansion in Africa.

Further reinforcing our R&D policy and our technical services, which are central to our business segments. We employ our technological solutions to meet the challenges of today's world in areas such as the sustainable city, transport, water, environment and energy. To address the challenges that lie ahead, we are stepping up R&D investment in our three business segments – soils, structures and nuclear. We believe that there is strong potential for discoveries and we are further developing our techniques to serve increasingly ambitious projects that respect people and their environment.

C O O R D I N A T I O N

•••

Prestressed concrete has outstanding advantages. We must continue to exploit and further develop them through widespread use of the material in innovative structures. This will make the best use of materials and thus generate savings.

Manuel PELTIER
Managing Director, Freyssinet



•••

To keep pace with the trend towards large-scale design-build projects and Public Private Partnerships, we are taking a new look at excellence in client care and moving from a client-supplier to a win-win partnership approach.

Roger BLOOMFIELD
Chief Executive Officer, Terre Armée



Jérôme STUBLER
Chief Executive Officer, Soletanche Freyssinet

•••

From the start, our companies have been driven by innovation and entrepreneurship. They now have their broadest-ever portfolio of technologies and expertise.

Pierre-Yves BIGOT
Human Resources Director,
Soletanche Freyssinet



•••

The quality of our companies reflects the quality of our people. The best way to achieve and maintain the level of excellence we aim for is to plan our workforce, apply high standards in hiring and provide ongoing training for our people throughout their careers.

C O M M I T T E E

... We want to be more than just another civil engineering company. Our day-to-day goal is to understand the real project requirements so as to deliver suitable solutions. In that sense, it is crucial to build a client relationship based on trust.

Marc LACAZEDIEU
Managing Director, Menard



Didier VERROUIL
Executive Vice President,
Eurofrance, United Kingdom
and North America,
Soletanche Bachy



... Our ability to provide innovative processes and equipment is part of our DNA. It reflects the vitality of our company, sets us apart and gives us real competitive advantages. It also serves to channel the energy of our teams.



Yann GROLIMUND
Executive Vice President
/ Chief Financial Officer,
Soletanche Freyssinet

... The strength of our model lies in decentralisation combined with our commitment to strong common values that are compatible with our multicultural environment.



Bruno DUPETY
Chairman, Soletanche Freyssinet

... Soletanche Freyssinet's international network of Business Units, which is set to expand further, enables us to make the most of the growth of the construction market around the world and, at the same time, control the risks inherent in the sector.



Jean-Philippe RENARD
Executive Vice President, Central and
Eastern Europe, Asia Pacific, Latin
America, Iberian Peninsula and Major
Projects Division, Soletanche Bachy

... Excellence drives the development of our company and of our employees. It guides our strategy, strengthens our capabilities and catalyses energies for the benefit of everyone involved.

K E Y F I G U R E S



REVENUE
€2.5 BILLION

LOCATIONS IN
80
COUNTRIES

ORDER BACKLOG
€1.8 BILLION

OPERATING IN
100+
COUNTRIES

EMPLOYEES
20,000

REVENUE / BUSINESS SEGMENT

SOILS **61.8%**
STRUCTURES **26.7%**
NUCLEAR **11.5%**

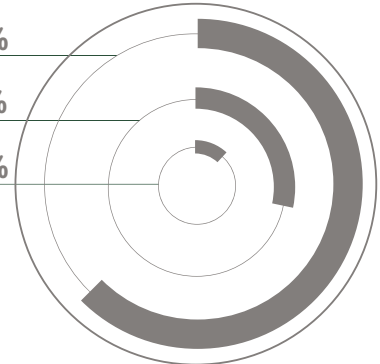

MANAGED WORKFORCE / BUSINESS SEGMENT

SOILS **52.5%**
STRUCTURES **35.8%**
NUCLEAR **11.7%**

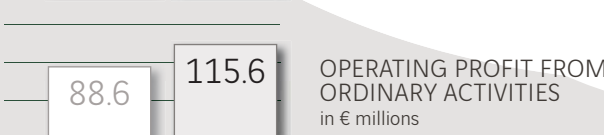
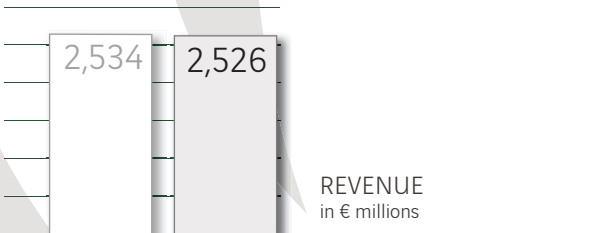
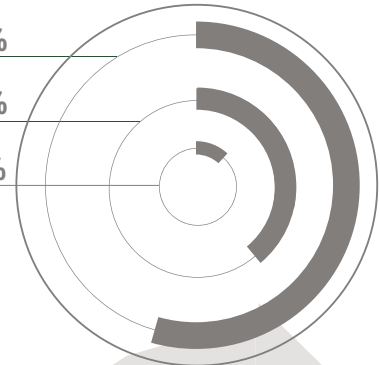

2012 2013

SOILS



Special foundations
and ground technologies

9,600 employees

€1,364 M revenue
managed revenue*: €1,450 M

down **2%** from 2012



Ground reinforcement
and improvement

900 employees

€197 M revenue

up **15%** from 2012

STRUC- TURES



Retaining structures
and precast arch tunnels

800 employees

€159 M revenue

down **21%** from 2012



Integrated technical solutions
for new construction
and structural repairs

6,400 employees

€516 M revenue
managed revenue*: €579 M

down **0.3%** from 2012

NU- CLEAR



Specialised expertise for
the nuclear industry

2,300 employees

€290 M revenue

up **15%** from 2012

* revenue including the share of revenue in jointly controlled companies



- ▼ Abu Dhabi
- ▼ Algeria
- ▼ Argentina
- ▼ Australia
- ▼ Azerbaijan
- ▼ Belgium
- ▼ Botswana
- ▼ Brazil
- ▼ Canada
- ▼ Chile
- ▼ China
- ▼ Colombia
- ▼ Costa Rica
- ▼ Czech Republic
- ▼ Dubai
- ▼ Egypt
- ▼ El Salvador
- ▼ France
- ▼ Germany
- ▼ Guadeloupe
- ▼ Guatemala
- ▼ Honduras
- ▼ Hong Kong
- ▼ Hungary
- ▼ India
- ▼ Indonesia
- ▼ Ireland
- ▼ Italy
- ▼ Japan
- ▼ Jordan
- ▼ Kazakhstan
- ▼ Kuwait
- ▼ Lebanon
- ▼ Macau
- ▼ Malaysia
- ▼ Martinique
- ▼ Mexico
- ▼ Monaco
- ▼ Morocco
- ▼ Mozambique
- ▼ Netherlands
- ▼ New Zealand
- ▼ Nicaragua
- ▼ Oman
- ▼ Pakistan
- ▼ Panama
- ▼ Peru
- ▼ Philippines
- ▼ Poland
- ▼ Portugal
- ▼ Qatar
- ▼ Reunion Island
- ▼ Romania
- ▼ Russia
- ▼ Saudi Arabia
- ▼ Serbia
- ▼ Singapore
- ▼ Slovakia
- ▼ Slovenia
- ▼ South Africa
- ▼ South Korea
- ▼ Spain
- ▼ Sweden
- ▼ Switzerland
- ▼ Thailand
- ▼ Turkey
- ▼ Turkmenistan
- ▼ Ukraine
- ▼ United Kingdom
- ▼ United States
- ▼ Uruguay
- ▼ Venezuela
- ▼ Vietnam
- ▼ Zambia

L O C A T I O N S

As a global and local group, Soletanche Freyssinet has a network of about 160 companies in nearly 80 countries across five continents.

REVENUE /
GEOGRAPHICAL AREA

EUROPE	50%
of which FRANCE	21%
NORTH AMERICA	16%
LATIN AMERICA	7%
ASIA	14%
OCEANIA	6%
MIDDLE EAST	5%
AFRICA	3%

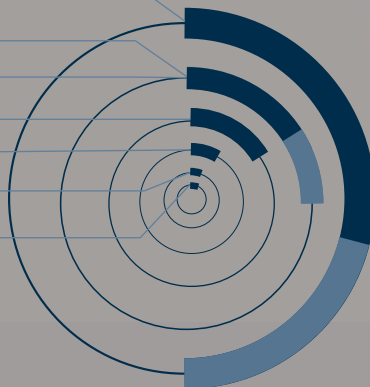

E X C E

L L E N C E

**The Soletanche Freyssinet Group strives to deliver
technical and human excellence to its clients.**

ZERO ACCIDENT SAFETY OBJECTIVE

Our absolute priority is to keep our employees safe and eliminate all dangerous situations. These goals are an integral part of each phase of every project. In keeping with our watchword *The Safe Way is the Only Way*, the Soletanche Freyssinet Group and each of its subsidiaries strive to achieve the zero accident objective.

In 2013, a Group-wide safety plan that each subsidiary tailors to its own circumstances was adopted. The plan is structured in three parts: health and safety rules; training; and safety targets.

Common health and safety rules applicable to all entities have been defined. They spell out the practical instructions to be followed in each Business Unit and on every worksite.

The Managing Safety training course held for the top managers in 2012 was extended to all management staff in 2013. It aims to strengthen the safety culture and boost involvement. The goal is for managers to set an example, drive day-to-day behavioural change and join their teams in a continuous improvement process.

Because safety is above all else a matter of risk control, the safety plan systematises detection and treatment of dangerous situations. A variety of initiatives taken across all Group subsidiaries have resulted in the elimination of nearly 15,000 dangerous situations.

In line with the plan, Soletanche Bachy, Menard, Freyssinet, Terre Armée and Nuvia have engaged in wide-ranging action to strengthen the safety of their employees around the world.



SOLETANCHE BACHY: SAFETY IMAGES

» As part of the series of annual films dealing with safety issues, Soletanche Bachy produced *"If I were to do it again"*. The film takes inspiration from true stories and aims to demonstrate the importance of behaviour by getting actors and workers to talk about how accidents happened and how they could have been avoided. Improvement initiatives were also taken across a variety of geographical areas. In Hong Kong, Malaysia, Singapore and Vietnam, for example, an awareness day was organised for all employees. In Singapore, the subsidiary introduced a continuous improvement programme designed to bring lasting change to its safety culture. In France, the *Cap Sécurité* seminar was held. The first one-and-a-half day session brought together the worksite management teams and the second the worksite employees.

2013 SAFETY INDICATORS

Frequency rate*

8.67

* Number of lost time workplace accidents x 1,000,000 / number of hours worked

Severity rate*

0.34

* Number of days lost due to workplace accidents x 1,000 / number of hours worked



FREYSSINET: AWARENESS AND PRACTICAL ADVICE

» In 2013, Freyssinet organised safety awareness raising seminars for its supervisory teams. In Mexico, for example, an event was held in conjunction with the local Terre Armée subsidiary. It brought together 160 supervisors including foremen. Meanwhile, Freyssinet published its Safety Guidance Notes and circulated them widely. The publication provides practical advice on a large number of themes such as the safety harness, scaffolding and personal protective equipment.

MENARD SAYS STOP

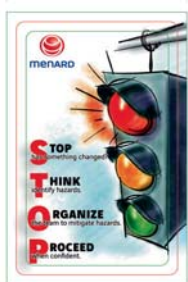

» **Simplicity is effective, as demonstrated by the STOP cards** devised by Agra Foundations and Geopac, subsidiaries of Soletanche Bachy and Menard in Canada. The system works as follows: when a dangerous situation is detected on a worksite, any person can hold up his or her STOP card. All activity then stops and is only resumed when the problem has been solved. Given the excellent results of this system, Menard has decided to roll it out across all its subsidiaries worldwide.

TERRE ARMÉE STEPS UP SAFETY IN DAY-TO-DAY WORK



» **Terre Armée set up new Stability and Safety procedures** to make safety a more clear-cut part of working procedures and methods. Even before the results of the new programme were in, the Brazilian subsidiary won the Vitae-Rio 2013 –

Construção Segura Empresa Viva award for its commitment to health and safety.

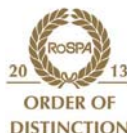

NUVIA: A BEHAVIOUR-FOCUSED PLAN

» In 2013, Nuvia France launched its new **La Sécurité Ensemble** safety plan common to all its subsidiaries in France. Designed to foster change in culture and in individual and collective behaviour, it was presented to the 1,300 Nuvia France employees by members of the Management Committee as part of an 11-stage "Tour de France". Meanwhile, Nuvia Limited won its second prestigious Order of Distinction awarded by the Royal British Society for the Prevention of Accidents (RoSPA). The award recognises Nuvia Limited's commitment to preventing accidents and health problems.

QUALITY, ENVIRONMENT: STRONG COMMITMENTS

Sustainable development underpins the Soletanche Freyssinet Group's values and strategy and forms an integral part of the solutions it designs and rolls out. Quality is a crucial driver of client satisfaction and of the Group's performance. Several actions were taken to boost sustainability and quality in 2013. An innovative, ambitious eco-design and eco-construction focus also enables the Group to support its clients, helping them to implement their own environmental programmes and comply with increasingly stringent standards.

Quality

SOLETANCHE BACHY COMPREHENSIVE QUALITY IN A FEW CLICKS

» **Soletanche Bachy introduced a new quality assurance plan in 2013.** Structured according to the Group's central functions (top management, safety, sensitive projects, sustainable development, finance, legal matters, communication, information systems) it sets out, in each area, the procedures, rules and recommendations that apply to all Business Units and operating divisions worldwide, supplementing each entity's own quality policy. The plan constitutes a common DNA and is accessible via the intranet. It is regularly expanded and updated.

NUVIA LIMITED FOCUS ON QUALITY MONITORING

» **In addition to its existing quality procedures, Nuvia Limited launched its Quality Observation Reporting system in 2013,** a discussion platform dedicated to quality and open to all employees. The purpose of the new tool is straightforward: to report problems and solve them efficiently and rapidly in a continuing improvement process.

Environment

ENVIRONMENTAL FOOTPRINTS: A NEW, MORE EFFECTIVE PRISM



» **To better control the environmental impact of its projects,** Soletanche Freyssinet in 2011 developed Prism, an innovative tool for performing comprehensive quantified environmental assessments. The software does more than calculate greenhouse gas emissions. It builds on several indicators to assess the environmental impact of a project from the production of the materials to the end of the structure's service life. In 2013, the tool was further expanded to make it more intuitive and more versatile. It uses external (Ecoinvent, Base Carbone®) as well as internal guidelines to cover the full range of the Group's processes and products. Prism takes the specific features of each Group entity on board and serves as an efficient and effective decision-making tool for selecting the most effective solutions for projects.

QUALITY, ENVIRONMENT



AVERAGE GREENHOUSE GAS EMISSIONS IN 2013

72 gCO₂-eq* / € revenue
* grams of CO₂ equivalent

12 tCO₂-eq* / person
* tonnes of CO₂ equivalent

REPLACING MATERIALS WITH GREY MATTER TO REDUCE GREENHOUSE GAS EMISSIONS

» In more than 20% of its projects, the Soletanche Freyssinet Group offers alternative solutions that save materials. For example, the use of prestressing in a building floor avoids about one tonne of CO₂ for every 30 sq. metres of flooring.

CONTRIBUTING TO PROJECT ENVIRONMENTAL CERTIFICATION

» The LEED (Leadership in Energy and Environmental Design) rating system, which originated in the U.S. and is now used in more than 130 countries, is one of the reference standards for high environmental quality buildings. Soletanche Bachy helps its clients obtain LEED certification for their projects with respect to a number of criteria within its scope of work. The many projects in which the Group was involved that were LEED certified in 2013 included the Eiffel Palace in Hungary and the Torre Diana (1), Torre Manacar (2), Torre Mitikah (3) and Torre Patriotismo 201 (4) high-rise buildings in Mexico. Similarly, Soletanche Bachy undertakes to obtain the British BREEM (Building Research Establishment Environmental Assessment Method) accreditation for its clients' buildings through the solutions it implements. Projects certified in 2013 included the Eiffel Palace and the K4 office building in Budapest; and C530 Pudding Mill Lane (part of the Crossrail project), the Capitol Way (5) and B Sky B (6) buildings and Building 1 of King's Cross Central (7) in London.

LOCAL EXPANSION FOR GLOBAL GROWTH

The growth of the Soletanche Freyssinet Group is based on the expansion of its local business activities. To meet the needs of clients all over the world, Soletanche Freyssinet creates new subsidiaries and acquires new companies. Its local network has the benefit of its global expertise.

A dynamic external growth policy



MENARD BACHY CONSOLIDATES ITS FOUNDATIONS IN AUSTRALIA

» **The key acquisition of AFS in December 2013 consolidated Soletanche Freyssinet's operations in Oceania.** Founded in 2002 and based in Sydney, AFS has made a name for itself in recent years as a benchmark foundation and piling contractor in eastern Australia. The company expands Menard Bachy's range of geotechnical products and services in the region.



NUVIA EXPANDS ITS OFFERING IN CANADA

» **Nuvia acquired the Canadian Pico Envirotec company in December 2013.** The Toronto-based company specialises in the design and fabrication of geophysical and nuclear measuring instruments. It designs, manufactures and installs equipment and software used around the world in a wide range of mining exploration, oil and gas, environmental and engineering applications.



FREYSSINET

STEPS UP ITS OPERATIONS IN THE NETHERLANDS REPAIR MARKET

» **In January 2013, Freyssinet acquired Tebecon.** One of the leading repair contractors in the Netherlands, the company offers a wide range of solutions and techniques. The acquisition is part of Freyssinet's move to expand its repair activity under the Foreva® brand in a bid to become a world benchmark in the field.

New locations around the world

SOLDATA ACCELERATES ITS INTERNATIONAL EXPANSION

Within Soletanche Bachy, Soldata specialises in geotechnical, structural and environmental monitoring to control risks during construction and operation. It has locations in 14 countries and generates 85% of its revenue outside France. To strengthen its local roots and locations close to the world's major infrastructure projects, Soldata set up operations in three new countries – Australia, Chile and Qatar – in 2013.

NUVIA IN CHINA

» **Following its prestressing work at Chinese power plants,** Nuvia opened a new subsidiary in China. Based in Shenzhen, Nuvia China operates with the main players in the Chinese market. Nuvia is developing its products and services in the risk control, logistics and decommissioning sector.

MENARD SETS UP LOCATIONS IN NEW COUNTRIES

» **Menard, which generated 85% of its revenue outside France in 2013,** continued its strategy of setting up locations in new countries. The Group, which specialises in ground improvement, introduced new locations in Kazakhstan, Mexico, Colombia and Turkey in 2013.

Technical and commercial synergies

» **Strength lies in unity. To deliver the best possible solutions, the various Soletanche Freyssinet entities are developing technical and commercial synergies.** A case in point is the safety upgrade of the Puymorens tunnel (1) in France near the French-Spanish border. Alongside design-build consortium leader Freyssinet, Soletanche Bachy Tunnels worked to excavate the shelters and connecting tunnels and Tierra Armada España built the escape tunnel (supply of prefabricated elements for the concrete wall) and the "false tunnels" at the portals (20 metre long prefabricated frames).

On the Forth Replacement Crossing (2) project in Scotland, Vibro Menard worked with Soletanche Bachy to improve a 3,100 sq. metre area to ensure stability of the backfill used in the bridge access road.

In France, at the Fessenheim nuclear power plant (3), Nuvia, which built the cooling tank containment building, called on Soletanche Bachy to build the foundations (micropiles drilled to a depth of 25 metres) for a building located in a constricted area. Lastly, **in Macau, the local Soletanche Bachy office supported Menard in improving the ground during the bidding and construction works for the Wynn Cotai Casino (4).**

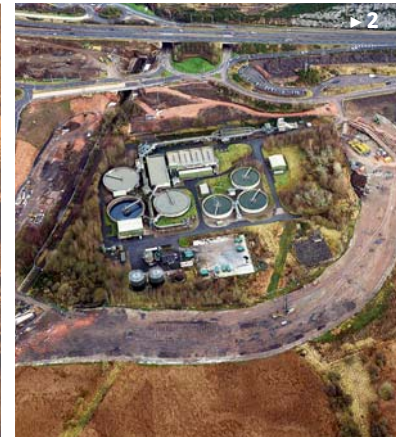

BUILDING EXCELLENT RELATIONSHIPS WITH CLIENTS AND PARTNERS

The Soletanche Freyssinet Group aims for excellence in the relationships it builds and maintains with each of its clients and partners. This means attentively listening to their needs, anticipating their expectations, consistently meeting commitments and offering high added value products and services.

SOILTEAM: THE MOST COMPREHENSIVE RANGE OF GEOTECHNICAL SERVICES

» In 2013, Soletanche Bachy and Menard joined forces to form the SoilTeam. The purpose of the network is to enable the two groups to deliver the best value-added solutions and provide global expertise through their local entities. The SoilTeam range of products and services covers the diverse needs of integrated geotechnically-focused projects and special works including deep foundations, retaining structures, strengthening and cut-off, local geotechnical specialities, centralised specialities (marine works, tunnels, monitoring, soil remediation) and ground improvement.

SoilTeam

FREYSSINET

» Freyssinet continues to help its clients extend the service life of their structures by reinforcing its diagnostic and repair project design capabilities and by diversifying its range of services to include structural and electrochemical repair services.

NUVIA EXPANDS ITS NUCLEAR MEASUREMENT SERVICES

» For more than 50 years, Nuvia has been involved in all phases of the nuclear facility life cycle. Building on this expertise, the Group introduced NuviaTech Instruments in 2013, a comprehensive and unique range of products and services dedicated to nuclear measurement and designed to detect and analyse all types of radiation to ensure the security of the fleet and the safety of people. The offering covers all the requirements of nuclear operators, service providers and contractors. Tailored to the industrial

issues faced by clients, it is based on the design of customised solutions. These can include components (digital detectors and analysers with associated software), equipment systems covering all fields of application (waste management, homeland security, environmental monitoring, radiation protection, laboratories, etc.) and services (nuclear measurements during operations, on-site measurement, surveys, modelling studies, etc.). The innovative approach taken by NuviaTech Instruments aims to deliver completely integrated services (manufacturing of equipment in the Group's own workshops) to ensure quality and competitiveness.



Client satisfaction



▶ **1.** On 27 September 2013 in Phoenix, Arizona, the Deep Foundations Institute (DFI) presented the Outstanding Project award to the Wolf Creek Dam Foundation Remediation Project, for which Soletanche Bachy renovated the foundations.

▶ **2.** March Construction (Menard) won the Canterbury Contractor of the Year Award presented by the New Zealand Contractors' Federation.

▶ **3.** Singapore's Land Transport Authority congratulated the Soletanche Bachy teams on "their positive and proactive attitude, completing the job with urgency and to a good quality" on the Telok Ayer station and associated tunnels for the metro system's Downtown Line 1.

▶ **4.** One year after its official opening in Vladivostok, Russia, the Golden Horn Bridge has become, along with the Russky Bridge, an emblem of the city. The crossing, for which Freyssinet installed the 192 stay cables, serves thousands of local residents every day, shortening their journeys and improving traffic flow.

▶ **5.** Freyssinet's Hammersmith Flyover project in London won the Institution of Civil Engineers (ICE) Special Award for Emergency Engineering in recognition of the rapid repairs carried out on the severely corroded structure.

SOLETANCHE FREYSSINET at the world's largest geotechnical gathering

At the 18th international conference on soil mechanics and geotechnical engineering in Paris from 2 to 6 September 2013, the Soletanche Freyssinet Group, a sponsor partner of the event, promoted its soil expertise. Five companies were represented (Soletanche Bachy, Menard, Terre Armée, Freyssinet and Soldata) on more than 5,000 sq. metres of exhibition space.

INNOVATING TO OPTIMISE PROJECTS

By placing research and development at the heart of its activities, the Soletanche Freyssinet Group prepares to meet the technical and economic challenges of the future. To constantly boost performance for the benefit of its customers, the Group pursues an ambitious innovation policy, which generated new useful and competitive solutions in 2013 and won a number of awards.

AWARDS FOR OUR INNOVATIONS

In 2013, the TDM and Cit'Easy were in the limelight. Designed by Soletanche Bachy's specialised subsidiary CSM Bessac to safely deconstruct tunnels, the TDM (Tunnel Dismantling Machine) was recognised by the Fédération Nationale des Travaux Publics (Equipment Process award) and the International Tunnelling Association (Innovation of the Year award). Developed by Soletanche Bachy to build diaphragm walls in urban areas, the Cit'Easy process won the Fédération Nationale des Travaux Publics Technical Process award.

A SUSTAINABLE GEOTHERMAL ENGINEERING INNOVATION: AN INNOVATIVE ENERGY AND SPACE SAVING COMBINATION

» Implemented to build 431 housing units for the **École Nationale de Techniques Avancées in France**, the GERP (Green Energies Reproducible Pack) designed by Soletanche Bachy made it possible to comply with a demanding energy saving specification within a limited land take. The solution consisted in coupling the field of geothermal probes with thermal solar panels on the roofs of the building. This process reduced the number of probes from 115 initially planned (for which there would not have been enough room) to 75. Thus optimised, the geothermal solution covered 100% of the domestic hot water needs and 90% of the heating needs of the units.



AN INNOVATION GENERATED BY A SUCCESSFUL SYNERGY TO PROTECT STAY CABLES FROM FIRE

» As part of the programme designed to upgrade the ANZAC cable stayed bridge in the port of Sydney, Freyssinet worked with Nuvia (Mecatiss, specialising in fire protection) to develop FCP 3000, an innovative fire protection solution. Commended by the client, it is made of prefabricated intumescent elements, a material that swells when there is a fire, thus protecting the stay cables from the heat source.

TERRE ARMÉE: 50 YEARS OF SUCCESSFUL INNOVATION

It all began with engineer Henri Vidal's thoughts about the combination of pins and sand. In 1963, after five years of research, he filed a patent for Reinforced Earth®. That set in motion a great adventure focused on innovation and development. A first subsidiary set up in Canada in 1970 was followed by others, for example in the United States in 1971 and Spain in 1972. Meanwhile, the technique was further developed over time. A half-century after the patent was filed, the Terre Armée Group operates on five continents and in more than 40 countries. Reinforced Earth® has come into widespread use in civil engineering across a broad range of applications: road and railway structures, mines, hydraulic engineering and facilities designed to protect or improve quality of life.



SOLETANCHE BACHY:
**PREFABRICATED PRESTRESSED
 CONCRETE SHEET PILING**

» **To optimise prefabricated retaining walls, Soletanche Bachy Cimas developed CZ-SOL walls.** The new range of walls has the geometry of sheet piling but the material used is prestressed concrete. This has a number of advantages: less concrete, greater inertia and a new and attractive architectural appearance. Four projects in Colombia have successfully used the new technique.

3D grouting monitoring

To manage complex grouting projects, 3D monitoring is now made easier thanks to Castaur View 3D. In an extremely crowded underground environment, this software provides efficient and effective 3D modelling tools to facilitate compensation grouting operations and ensure the safety of existing underground networks. For example, the grouting results (pressure/volume, lift) are superimposed on 3D as-built models to provide a good overview and optimise the Crossrail project worksites in London.



MENARD: GROUND
 IMPROVEMENT EQUIPMENT
 THAT USES LESS ENERGY

» **To reduce energy consumption** of its ground improvement equipment, Menard has designed a new-generation electrical cabinet for the V23 and V48 vibrators used in vibro-compaction and stone columns. Combining a variable frequency drive with a power PLC and a monitoring interface, it offers a range of benefits: a substantial reduction in the size of generators, which saves energy, a significant increase in the service life of vibrators, which reduces maintenance costs, and easier control of the vibrators thanks to a new, more intuitive monitoring interface.

NUVIA FRANCE:
 SEISMIC DAMPERS FOR
 NUCLEAR FACILITIES

» **Following the Fukushima accident,** nuclear operators decided to reinforce their facilities to protect them from natural events. Nuvia Travaux Spéciaux has developed a technology that dissipates energy by means of viscous Freyssinet dampers placed between buildings. The solution reduces the displacement of flexible structures and avoids impact between contiguous buildings.



FREYSSINET: MORE
 COMPETITIVE WIND TURBINES

» **To make wind energy more competitive compared to fossil fuels,** Freyssinet devised a new type of prestressed concrete tower to replace conventional steel towers. Called Eolift, the project, which is currently being developed, consists in building a 120 metre high prototype equipped with a 3 MW turbine. An industrialisation innovation accompanies the structural innovation: to avoid the use of a very large capacity crane, an innovative tower erection and pod assembly tool was designed. Eolift aims to reduce the construction and foundation cost of high-capacity wind turbines by 15%.



NUVIA LIMITED: A MODULAR PLANT
 TO TREAT ACTIVE EFFLUENTS

» **Nuvia Limited has developed a modular active effluent treatment plant (the MAETP)** that meets the client's requirements. The design integrates the effluent treatment plant and the equipment and control room in two containers that can be assembled and tested off site, and then rapidly delivered, installed and connected to existing effluent inflow and outflow pipes. This modular solution substantially reduces the cost of treatment compared to conventional plants. Ultimately, Nuvia Limited plans to use the solution for other sites being decommissioned, repaired and maintained.

EMPLOYEE DEVELOPMENT AS AN EXCELLENCE DRIVER

To give its clients the benefit of the best possible expertise, the Soletanche Freyssinet Group is committed to constantly developing and expanding the skills of its employees. Some of the initiatives taken in 2013 to foster the sharing of best practices within an international group are described below.



A CULTURE COMMON TO JUNIOR MANAGERS AROUND THE WORLD

» **The wide-ranging backgrounds and expertise of the Soletanche Freyssinet Group's employees are its main asset.**

The bond that brings them together around a common identity and common values further enhances it.

To foster this cohesion, the second junior manager integration seminar was organised in 2013. 160 managers from 40 countries gathered in Paris for three days in September to discuss the various aspects of the Group's strategy, including safety, innovation, human resources, communication, finance and sustainable development.

Focusing on the conference theme - "passion" -, workshops provided an opportunity for discussion with other employees who came to present a project, activity or career path.

80
nationalities
represented

76%
unlimited-
term
contracts

over
130,000
hours of training
in health and safety

53%
of employees
work outside Europe

16%
women
managers

over
7,000
hours of training
in environmental issues, including
over 200 hours focused on eco-design

38
average
age



SOILTEAM ACADEMY: THE SOILS BUSINESS SEGMENT MOVES ONLINE

» Building on the SoilTeam momentum, the human resources department has set up a multilingual training platform, the SoilTeam Academy.

The platform, available to employees of the Soils business segment, brings together the full range of existing training resources. In addition to a company library (training courses, videos), the SoilTeam Academy offers a wide variety of e-learning modules to enable every employee to receive training when and where he or she wishes on subjects ranging from concrete to safety habits.



THE NUCLEAR ATTITUDE WITH THE IFCEN

» IFCEN, the first nuclear environment training institute, provided training to support the action taken by the Essor and NTS (Nuvia France) teams to instil a better understanding of unit outages. The idea is to develop each employee's "Nuclear Attitude" by providing a detailed description of the requirements, goals and risks involved when working in a nuclear environment. Each employee can thus make an active contribution to enhancing performance. With the IFCEN, Soletanche Freyssinet offers recruitment, training and expertise activities for all nuclear players. A dedicated qualification training centre is currently being built in Pierrelatte, France.



PM+ TRAINING IN PROJECT MANAGEMENT

» Initiated in 2012 within the Soletanche Freyssinet Group, the PM+ training programme was stepped up in 2013 in the countries where the five companies operate. The six-day course is designed to enable project managers to share the same project management methods, from contract signature to closeout, as well as the Group's safety, quality and profitability standards. Exchanges of best practices and network development are also a focus of attention, with experienced engineers and experts participating. In 2013, more than 350 project managers took this strategic course designed to enhance project management and client satisfaction.



SOILS

A C T I V I T Y

STRUCTURES

A large, stylized white letter 'W' is positioned on the left side of a dark gray background. The letter is composed of several geometric shapes, including triangles and rectangles, creating a modern, abstract look. The right side of the image is a solid dark gray.

NUCLEAR





SOILS

The last pile is installed on the Port of Sept-Îles project (Canada), on which Soletanche Bachy's subsidiaries Bermingham and Balineau (marine works) worked.



SOLETANCHE BACHY

As a world benchmark in foundations and soil technologies, Soletanche Bachy delivers a comprehensive range of geotechnical processes, special foundations, underground works and soil improvement and remediation techniques.

In 2013, Soletanche Bachy recorded slight organic growth, notably as a result of its dynamic Major Projects activity and good performance in the United Kingdom and Asia. Also noteworthy were the excellent results of its monitoring subsidiary Soldata. Soletanche Bachy's teams helped implement a very wide range of projects throughout the world, including railway lines, factories, dams, tunnels, high-rise buildings, metro systems and port infrastructure. A large number of orders were also booked during the year in France (Port Est on Reunion Island, Flamands quay in Cherbourg, Nice light rail system), Poland (Łódź light rail system), the United States (Wolf Creek Nuclear Discharge), the United Kingdom (additional phases of the Lee Tunnel project), Cameroon (Wouri Bridge), Dubai (Mall of the Emirates car park), Asia (Macau bridge, Xiqu Opera, Link Road and SCL 1112 metro line in Hong Kong, Saigon Centre (phases 2 & 3) in Ho Chi Minh City, Ikea and Boustead shopping centres and Bukit Bintang metro station in Kuala Lumpur) and Latin America (Reforma 509 tower in Mexico, Siemens jetty in Argentina).

**T6 light rail in France
(Châtillon-Vélizy-Viroflay)**

CEVA rail link in Switzerland

**Crossrail and Lee Tunnel in the
United Kingdom**

LEGO plant in Hungary

Al Hoceima Dam in Morocco

Port of Lomé in Togo

**Terminal 3 at Jebel Ali Port
in the United Arab Emirates (Dubai)**

Port of Sept-Îles in Canada

El Teniente mine in Chile

**Wolf Creek Dam, Columbia
University, Port of Miami tunnel,
Provo Temple in the United States**

**Reforma, BBVA Bancomer
and Mitikah 2 towers in Mexico**

Puerto Brisa in Colombia

**DUO high-rise buildings project,
metro line and National Art Gallery
in Singapore**

**Central Wan Chai Bypass, metro lines
in Hong Kong**

Metro line in Malaysia (Kuala Lumpur)





“The talent of the teams working on this high-profile, high-risk project enabled us to complete it successfully. Their total commitment was the decisive factor in restoring the full potential of the key infrastructure for the region and the country.”



Jean-Luc GOBERT

Major Projects Director,
Soletanche Bachy

WOLF CREEK DAM
(KENTUCKY, UNITED STATES)

An “outstanding” project completed nine months ahead of schedule

Soletanche Bachy completed the remediation work on the foundations of the Wolf Creek Dam in record time. The 1,748 metre long, 78.5 metre high structure was suffering from regressive erosion. The project, handed over nine months ahead of schedule, was named Outstanding Project of the Year by the Deep Foundations Institute (DFI). This is a source of pride for the teams committed to the project over a period of four and a half years, who worked for 2.3 million hours to build a 91,000 sq. metre, 85 metre deep cut-off wall combining secant piling and panels protected by a 52,000 sq. metre, 1.8 metre thick diaphragm wall.



LAKE NYOS DAM (CAMEROON)

Reinforcing for protection

Following the natural disaster in 1986 involving a massive carbon dioxide eruption, a large number of experts focused on Lake Nyos and the gas issue. Many studies showed that the natural dam impounding Lake Nyos required reinforcement to avoid flooding and renewed gas release. Soletanche Bachy's Major Projects department carried out the technically and logistically challenging project at the isolated site. Many obstacles had to be overcome to implement the 10,500 linear metres of jet grouting and 60 tonnes of cement had to be delivered every day. The teams rose to the challenge.





**CEVA RAILWAY LINE
IN GENEVA
(SWITZERLAND)**

**Cut-and-cover
tunnels on track**

The creation of a regional express line to link Geneva's Cornavin station with the Annemasse station in France, first suggested in 1912, is now coming to fruition with the planned 16 km CEVA (Cornavin-Eaux-Vives-Annemasse) railway link, which will provide a practical and ecological solution to urban transport in the French-Swiss Geneva area.

Soletanche Bachy France and Sif Groutbor won four works packages for the large project. They will be building several kilometres of cut-and-cover tunnels as part of the works. One tunnel, with a length of 1,510 metres, is located in the heart of Geneva's residential neighbourhoods and the other at the underground Eaux-Vives station in Geneva, at a depth of 16 metres.



**NATIONAL ART
GALLERY
(SINGAPORE)**

**Technical
capabilities
serving the
heritage**

Designed to exhibit 19th and 20th century Southeast Asian painting, the 60,000 sq. metre National Art Gallery will open to the public in 2015. The project involves

the renovation of two buildings that have Singapore heritage status. Bachy Soletanche Singapore worked on the foundations. The challenge was to build the walls for the museum's underground levels around and within the buildings, which originally had shallow foundations or were erected on piles that are now 70 years old. The bridging technique, often

employed under utility networks, was adapted to dig under the facades and provide continuity of the diaphragm wall. The teams made the most of the company's small-boom excavation expertise to work inside the two buildings.

**PUERTO BRISA
(COLOMBIA)**

**Coal carriers
in safe harbour**

Local Soletanche Bachy subsidiary Soletanche Bachy Cimas and the Group's Major Projects department once again demonstrated their expertise in port infrastructure on the huge Puerto Brisa project in Colombia. To enable the coal carriers to be loaded offshore, the teams designed and built a 1,180 metre long, 8 metre wide jetty linked to a 380 metre long, 22 metre wide quay.

The structures were handed over after three years of works in November 2013. They rest on several hundred driven metal piles covered with prestressed concrete slabs. To maintain the natural heritage, special attention was paid to managing, sorting and either recycling or providing for appropriate disposal of ordinary, hazardous and recyclable waste.





From design to construction, Menard implements innovative foundation solutions based on high-performance ground improvement and reinforcement processes. The treatment makes construction possible on otherwise unsuitable soils or eliminates the need for deep foundations in a wide variety of projects.

Menard's revenue grew by a substantial 8% in 2013. This performance is due, among other things, to brisk business in Asia, the United States and the Middle East, where the economy is recovering. Menard also initiated or completed a diverse range of large projects (airports, bridges, waterfronts, ports, water treatment facilities, etc.) in Scotland, Canada, Italy and New Zealand.

Major new contracts were added to Menard's order book in France (SEA high-speed line), the United Kingdom (Bexhill-Hastings road) and Canada (Tsawwassen Mills Mall in British Columbia).

Forth Replacement Crossing in the United Kingdom (Scotland)
Porto di Vado container terminal in Italy (Genoa)

Jeddah South and Yanbu 3 thermal power plants in Saudi Arabia

SARB islands, Jumana island, Bluewater island and the Pointe at Palm Jumeirah in the United Arab Emirates

Prologis and Goya Foods warehouses in the United States

Vancouver International Airport, Shell Quest Carbon project and Northfield Bridge in Canada

Terminal 3 at the Jakarta airport in Indonesia

Ichthys LNG and Barangaroo seafront in Australia

Oxidation ponds at the Christchurch wastewater treatment plant in New Zealand

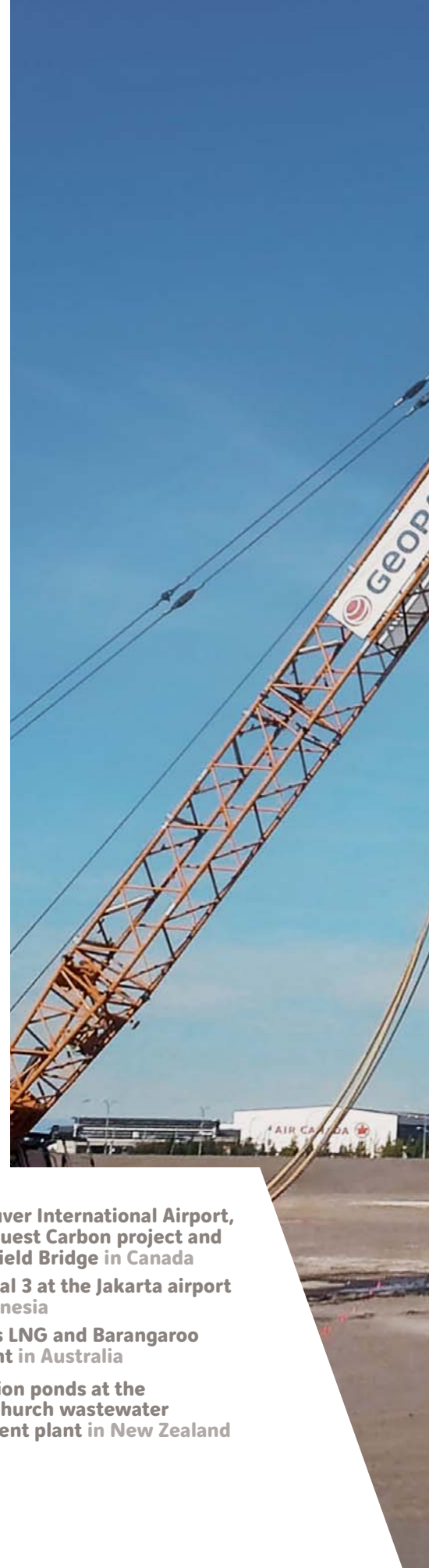



“The seismic context in this area offers scope for ground improvement techniques. In recent years, Geopac has carried out most of the soil densification works for the Vancouver airport. It proposed a solution that does not require predrilling, while preventing spoils from rising and thus controlling the risk of pollution.”



Philippe LIAUSU
Chief Operating Officer,
Menard

VANCOUVER
AIRPORT (CANADA)

**Vibroflotation
and Franki piles:
a successful
combination**

To cope with steadily increasing air traffic, the Vancouver International Airport (YVR) launched in 2013 two major developments in 2013 that called for additional work by the Canadian subsidiaries of Menard (Geopac) and Soletanche Bachy (Agra Foundations). In the first project to extend the international terminal, Agra Foundations installed Franki type driven piles to support the building structure and Geopac densified the soil, which was prone to liquefaction in the event of an earthquake, by means of vibro-densification using the wet method with the addition of ballast. The worksite teams successfully applied the combined techniques of the two groups in a restricted area with an existing road. The same client then asked Geopac to treat the soil under the Templeton outlet centre, similarly at risk of liquefaction, using the same densification method. The project, which extends over a 44,000 sq. metre area, is located at the end of one of the runways and the work was carried out in compliance with air traffic standards.



FORTH REPLACEMENT CROSSING (UNITED KINGDOM)

Nearly 4,500 CMCs under the road

Menard and its British subsidiary Vibro Menard won the contract to work on the Forth Replacement Crossing. The project, one of the United Kingdom’s largest currently under construction, involves a road suspension bridge with a metal deck over the Firth of Forth 15 km from Edinburgh.

Menard won the contract to improve the soil under the access road backfill on the northern bank. A French-British team stabilised the backfill using 4,451 controlled modulus columns (CMCs).

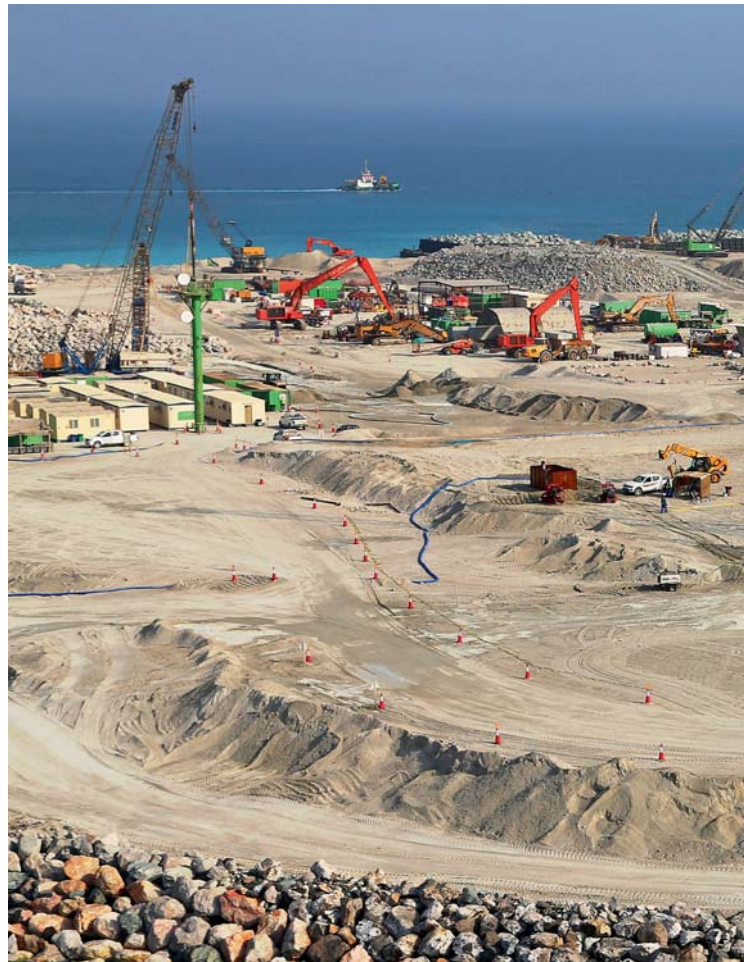

GAS TERMINAL (BRUNEI)

Stone columns in difficult soil

The construction of a new 78 metre diameter liquefied natural gas storage tank at the Brunei gas terminal gave Menard an opportunity to demonstrate the scope of its expertise. After modelling the condition of the soils (successive layers of sand and clay of variable thickness) under the area where the structure was to be built, the company proposed a ground improvement

solution based on stone columns in order to accommodate the schedule of the project, which was to be carried out while the complex was in operation. Advanced 3D modelling was performed throughout the project to ensure compliance with stringent criteria applying to differential settlement between the centre and the edge of the tank.



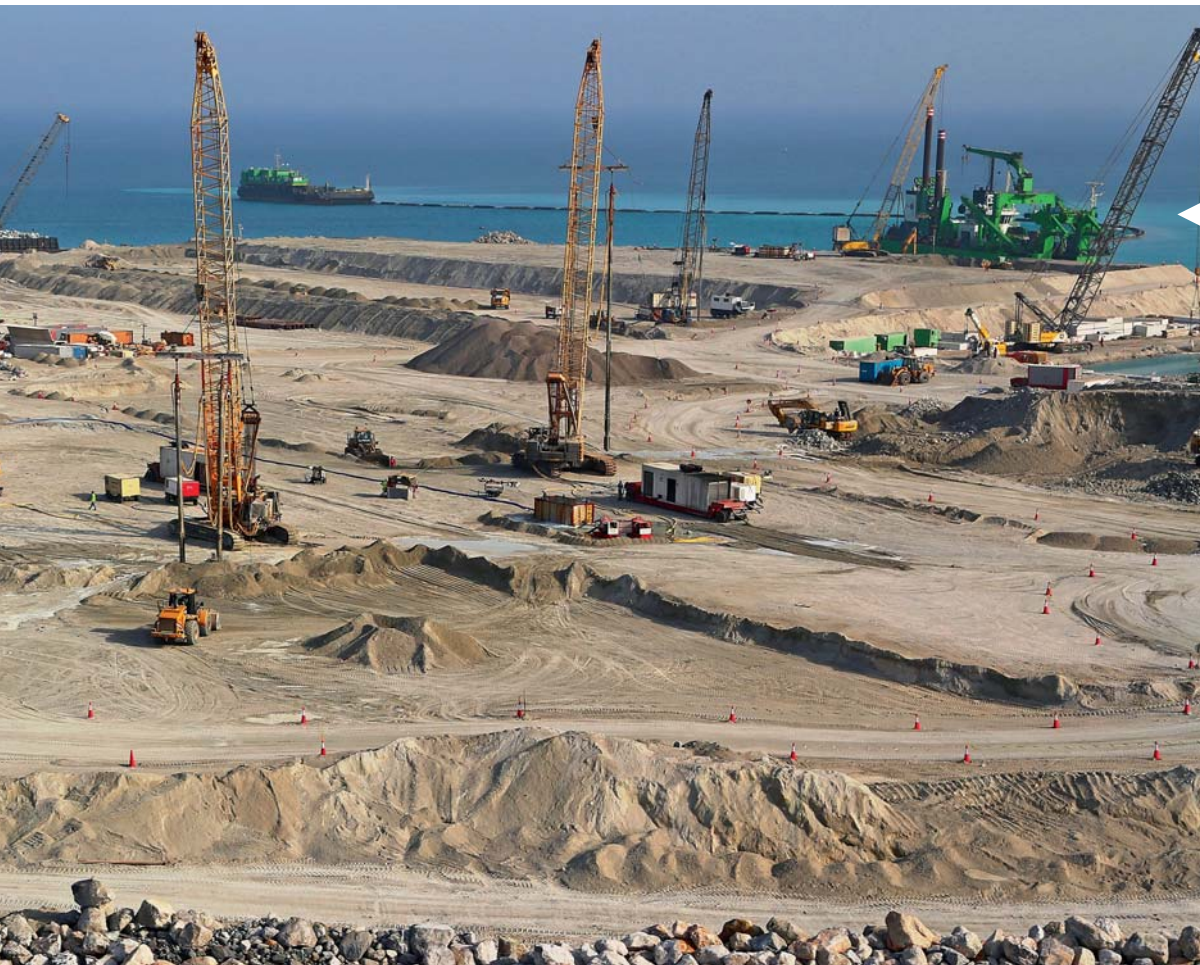

**SARB 1 & 2 ISLANDS
(EMIRATE OF ABU
DHABI)**

**Vibrocompaction:
a wealth of
resources in
the soil**

The SARB-1 and SARB-2 islands 130 km off the coast of Abu Dhabi are being refurbished and built to extend the capacity of the Satah oilfield. As part of the ambitious and complex project, Menard Vibro, which had previously carried out a similar project on another island, was asked to support the company carrying out the works. In addition to providing geotechnical advice, Menard's assignment includes ground improvement using vibrocompaction to a depth of 24 metres.



**CHRISTCHURCH
WASTEWATER
TREATMENT PLANT
(NEW ZEALAND)**

**Treatment
following the
earthquake**

After the February 2011 earthquakes damaged the sewer system in Christchurch, the city awarded a contract to Menard's New Zealand subsidiary March Construction to carry out rehabilitation and ground improvement works on the infrastructure. The state-of-the-art vibrocompaction technique was used to rebuild the banks of the oxidation ponds and treat the soil to prevent liquefaction. The project also included the construction of 51,000 linear metres of access roads and three hydraulic structures to channel water from the ponds to the estuary.







STRUCTURES

Freyssinet built the Consol Energy Wing Tip Bridge over the New River Gorge in Mount Hope, West Virginia (United States) as general contractor.



TERRE ARMÉE

Terre Armée, world leader in earth retaining structures and a specialist in precast arch segments for cut-and-cover tunnels, brings its one-of-a-kind proprietary technologies and processes to major infrastructure projects around the world.

Following exceptional growth of 26% in 2012, Terre Armée remained on track to achieve its sustainable growth objectives despite a decline in activity in 2013, which was due to the sharp downturn in mining activity in a number of countries and a slackening of the roadworks markets in Europe and India. Although volume was slightly down, activity remained brisk in the United States thanks to contracts for large projects such as the Grand Parkway in Texas and the Ohio River Bridges in Indiana and Kentucky. Other highlights of the year included road projects in Spain and Brazil, mining projects in Chile, airports in the United States and large-scale railway projects like the SEA HSL, for which eight Reinforced Earth® structures were built, the first time they were used on a high-speed railway line in France.



SEA HSL in France

Extension of the Pamplona motorway in Spain

Extension of the Fort Lauderdale, Florida airport in the United States

Antucoya mine in Chile

Baía de Todos os Santos expressway in Brazil (Salvador de Baía)

Gateway WA project in Australia (Perth)



"This Reinforced Earth® wall is the most impressive I have ever seen. I am very proud of having been part of the team that achieved this technical feat. This challenging project illustrates the company's technical capabilities and commitment to its clients."

● ● ●
Jack STEWART,
Regional Director, RECo, USA

FORT LAUDERDALE,
FLORIDA (UNITED
STATES)

**Set to land
the A380**

To increase capacity, the Fort Lauderdale airport in Florida has undertaken a large extension project aimed at building new runways and taxiways above a motorway and a railway line. As part of this project, Terre Armée's local subsidiary Reinforced Earth Company (RECo) raised the ground level by 18 metres at one end of the site. To achieve this configuration, it designed and built more than 27,870 sq. metres of Reinforced Earth® walls. These structures, ordinarily used in motorway applications, were designed to particular specifications. The project used "high adhesion" reinforcing with ribs. This product, known to perform well in high walls, will enable the structure to withstand heavy loads such as those imposed by an Airbus 380 plane.

GATEWAY WA (AUSTRALIA)

26,000 sq. metres of TerraTilt® panels

The Reinforced Earth Company (RECo) Australia won the highly competitive bidding for the contract to design and supply retaining walls for the Gateway WA Perth Airport and Freight Access project in Perth, Western Australia. The AU\$1 billion project is the largest ever carried out by Main Roads WA, the State highway authority. The goal is to improve the safety and efficiency of one of the country's main transit hubs, where road, rail and air transport systems

intersect. Over a period of 18 months, RECo Australia will supply 26,000 sq. metres of concrete TerraTilt® panels in all heights, which will be used to build bridge abutments and other structures required for the project.



SEA HSL (FRANCE)

20 Reinforced Earth® walls along the Tours- Bordeaux high- speed line

In the autumn of 2013, Terre Armée delivered the first walls along the impressive SEA (South Europe Atlantic) high-speed line near Tours. The project will consist of 302 km of new track between Tours and Bordeaux to connect the latter to Paris in 2 hours and 5 minutes. The first structure comprises two walls with a combined

length of 170 metres and a maximum height of 11 metres, forming an area of more than 1,000 sq. metres. Overall, there will be 20 Reinforced Earth® walls spread across eleven structures, including eight flyovers, an underpass and two road bridges. Completion is scheduled in the spring of 2014. This is the first time the Reinforced Earth® technology has been used on a high-speed railway line.





ANTUCOYA MINE (CHILE)

Composite Earth®, a seam to be mined

The Tierra Armada Chile teams built four 12 metre high retaining walls in less than two months at the Antucoya copper mine north of Antofagasta in Chile. The Chilean subsidiary of Terre Armée took on the design, engineering and execution of the works at the mining site, where the soil has a high salt content. The highly innovative, patented Composite Earth® system was used to minimise structural displacements. The turnkey wall solution was a major factor in the success of the project, which was completed without accident thanks to compliance with safety procedures.



HEADS OF THE VALLEYS ROAD (UNITED KINGDOM)

The U.K.'s highest TechSpan® segment

As part of the A465 project, which is widening the motorway to a dual two-lane carriageway in southern Wales, the Reinforced Earth Company UK delivered the country's highest-ever arch structure. Because of its location on a slope, the structure, which has the highest backfill above a TechSpan® arch in the United Kingdom, required customised manufacturing of the elements. The technique was used to install the structure more easily and safely. The record-setting project was designed by employees from several group entities.



A benchmark in specialised civil engineering, Freyssinet is the world leader in its specialised expertise: prestressing, construction methods, cable structures, structural equipment; and structural repair, reinforcement and maintenance with its Foreva® solutions.

In 2013, Freyssinet's business volume held steady at an excellent level. Strong growth in geographical areas such as the Middle East, the Benelux countries, Asia and France offset a decline in such countries as Spain, Poland and Mexico. Major projects in Saudi Arabia, Switzerland, Mexico and China set the pace in 2013. Freyssinet's order backlog increased by 24% compared to 2012 thanks to exceptional order intake with a value of more than €600 million.

Major contracts included the third bridge over the Bosphorus in Turkey (supply and installation of stay cables), the metro viaduct in Ho Chi Minh City, Vietnam, the Coatzacoalcos Bridge in Mexico and the Grota Bridge in Poland (repairs) and 13 bridges in Macedonia.



Puymorens Tunnel in France
La Poya Bridge in Switzerland
Haliç Bridge in Turkey
Dammam Bridge and Briman reservoirs in Saudi Arabia

El Carrizo Bridge in Mexico
Tangshan LNG project and Yangjiang power plant in China
MLC Tower in Australia



“Freyssinet was involved very early on in the design of the bridge, which links the Taksim neighbourhood with the historic peninsula in Istanbul. It took ten years to overcome the technical difficulties and to build this elegant structure supported by stay cables of unequalled durability.”



Pierre MELLIER

Director, Central and Eastern Europe, Freyssinet

**HALIÇ BRIDGE
(TURKEY)**

A metro bridge over the Golden Horn

The Haliç Bridge, opened in mid-2013, provides a fourth span across the Golden Horn estuary in Istanbul. The monumental 919 metre long structure is made up of two access viaducts, a cable-stayed bridge and a swing bridge. It accommodates a metro station on its main span and supports an extension of a metro line, raising its capacity from 200,000 to 750,000 passengers per day. Freyssinet’s Turkish subsidiary Freysaş and the Group’s Major Projects department produced and installed the stay cables on the 387 metre bridge and provided the prestressing, abutments and arch lifting works. Working in a protected historic landmark site, the teams paid particular attention to preserving archaeological objects and the view of the city’s historic monuments.



OLD TOH TUCK ROAD WAREHOUSES (SINGAPORE)

Post-tensioned flooring for heavy loads

In 2013, Freyssinet took part in the construction of a large number of buildings with post-tensioned flooring. This solution was used, for example, in a five-level industrial building west of Singapore. It was designed and installed to house several warehouses and needed to be able to support heavy loads while leaving open space to accommodate delivery vehicle traffic.

Post-tensioning proved to be the optimum solution for the project. Freyssinet was involved in the early design of the building and was then in charge of supplying and installing 26,700 sq. metres of prestressed flooring and 300 tonnes of prestressing strands.



MLC TOWER (AUSTRALIA)

Foreva® solutions take to the skies

The iconic 220 metre tall building on the Sydney skyline, the octagonal MLC Tower, built in 1978, is undergoing a comprehensive facade refurbishment. Freyssinet, in charge of the project, proposed Foreva® Galvastar cathodic protection solutions to avoid concrete corrosion and Foreva® Fuge SILC solutions to protect the surfaces.

To minimise disruption for the occupants of the tower and the adjacent buildings during construction work, a challenging system involving work zone encapsulation and four work platforms was introduced. Designed and developed for the purpose, the platforms were progressively raised along the facades by telescopic mast columns.

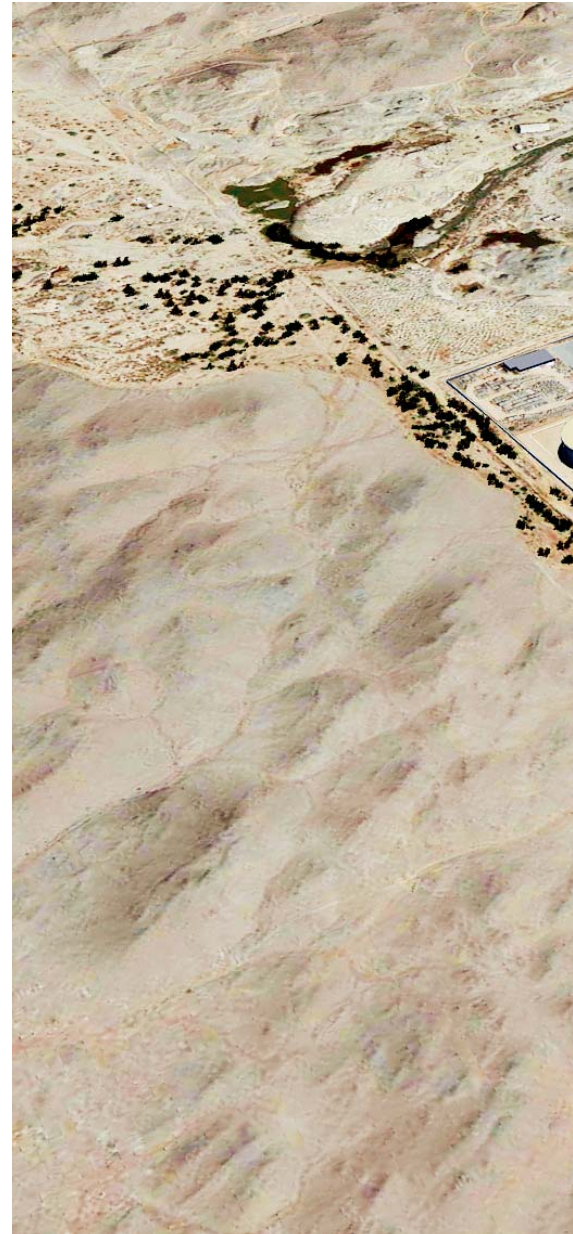

PUYMORENS
TUNNEL (FRANCE)

**Fire safety:
Freyssinet in the
heat of the fray**

The 4,820 metre long Puymorens road tunnel near the French-Spanish border is undergoing an extensive upgrade to standards. Thermal protection, achieved by installing 40,000 sq. metres of Promat plates; nine shelters to evacuate the public; and a concrete escape tunnel. The entire range of fire protection systems is installed under the oversight of Freyssinet, which is responsible for designing

and implementing the wide-ranging programme. Two additional Soletanche Freyssinet entities, Soletanche Bachy Tunnels and Tierra Armada, are also involved in the project, carried out in two phases. One phase was completed in November 2013 and the second will begin in the spring of 2014.



BRIMAN RESERVOIRS
(JEDDAH, SAUDI
ARABIA)

**Prestressing
for blue gold**

In a region subject to drought, where extreme heat waves are a frequent occurrence, the construction of the Briman drinking water tanks is a strategic move for Jeddah, Saudi Arabia's second-largest city. The oversized infrastructure consists of eight 120 metre diameter tanks with 18 metre high walls. Each tank has a capacity of 187,500 cubic metres. Freyssinet was selected to provide the prestressing in the walls of these reservoirs, which are designed to provide emergency backup in the event of a water supply system failure or a natural disaster.

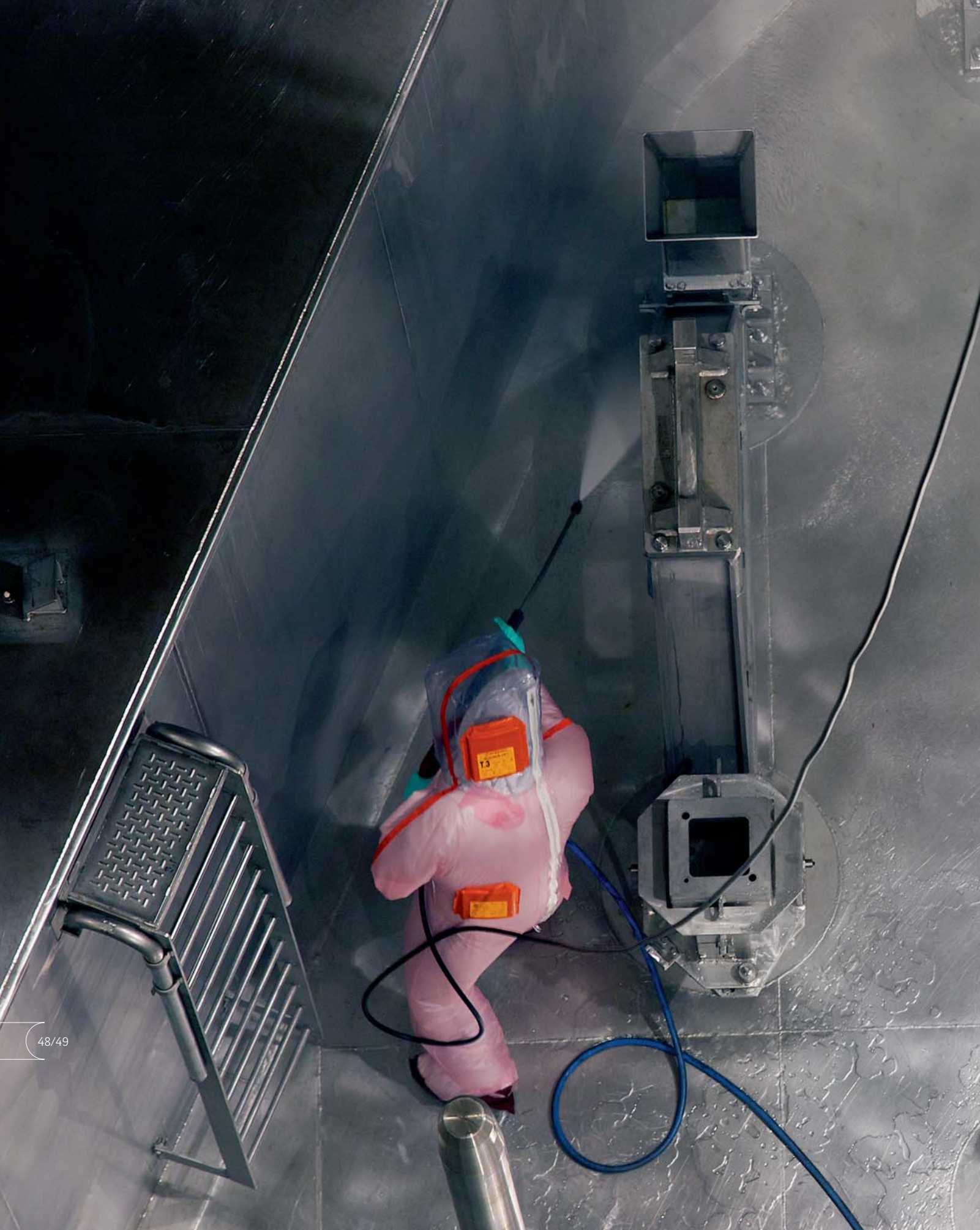



NUCLEAR

Decontamination of the reactor building cooling pond
at EDF's Cruas-Meysses power plant in France.



Specialising in civilian and military nuclear facilities, Nuvia works on all stages of the life cycle: authorisation, construction, operation, maintenance decommissioning and waste management.

In 2013, Nuvia recorded growth of 15% mainly as a result of brisk activity in France, the United Kingdom and the Czech Republic, where Envinet successfully completed its first year within the Nuvia Group. The Group extended its international network with the creation of subsidiaries in China (Shenzhen) and the United States (Charlotte, NC), the opening of an office in Abu Dhabi and the integration of Pico Envirotec in Canada (dynamic geophysical and nuclear measurement).

NUVIA FRANCE

Nuvia France operated primarily at French nuclear sites, providing logistics, radiation protection and overall worksite assistance at Cruas, Dampierre and Penly; design-build construction of installations at Fessenheim; and decommissioning at Cadarache, Marcoule, Creys-Malville and La Hague. Outside mainland France, the company continued decommissioning work at Ispra in Italy and the sale of its risk protection products in the international market.

CEA CENTRE
(FRANCE)

Millennium prepares the future of nuclear research

Millennium offers proven expertise in turnkey design of nuclear facilities. Following the Concept and Basic Design phases, teams continued to coordinate research on the construction of an experimental physics laboratory. Additionally, Millennium is currently using its state-of-the-art, acknowledged expertise

in risk management to design transport packaging for radioactive materials and manufacture gloveboxes to treat radioactive waste.



WOLSONG POWER PLANT (SOUTH KOREA)

Mecatiss streamlines safety

The Mecatiss teams carried out their first fire protection project in South Korea. The project consists in supplying the MPF 2000 cable tray protection system in the Unit 1 reactor building at the Wolsong power plant on South Korea's east coast.

The award went to Mecatiss based on an important criterion in the post-Fukushima period, when earthquake resistance is a primary concern: the MPF 2000 system is the most streamlined system currently available.



FESSENHEIM POWER PLANT (FRANCE)

Essor: comprehensive reactor shutdown expertise

In 2013, Essor worked on nine reactor shutdown projects, confirming its expertise and its ability to provide innovative solutions. In addition to overall worksite support at EDF's Penly, Cruas and Dampierre power plants, the teams completed a variety of assignments: radiation protection at several EDF and CEA sites,

nuclear logistics for the Toulon DCNS and decontamination at the Fessenheim (photo) and Bugey sites. A new underwater aspiration system and a robot used to decontaminate the transfer tube between the reactor ponds and fuel buildings were specially designed for the latter operations.

BUGEY POWER PLANT (FRANCE)

Compliance upgrade with NTS

Following the design-build construction of a building to cover the PTR (contaminated effluents storage tank) in Unit 1 in Fessenheim, which can withstand a strong earthquake as well as such natural phenomena as storms, NTS was awarded the contract to do the same implementation on Unit 2. Another highlight of the year was the resumption

of a historic NTS activity: compliance upgrades of the prestressing ties used to attach large components and support civil engineering pipes (see photo).



ISPRA SITE (ITALY), CEA AND AREVA SITES (FRANCE)

Salvarem: unique decommissioning expertise

As part of the multi-year decommissioning contract at the former Ispra nuclear research centre (Italy), which began in 2010, Salvarem carried out several major projects in 2013, including the dismantling of a former radioactive waste intermediate storage pond. Salvarem also worked on the Magnesium transporter decommissioning project at MAR400 (Marcoule).

An industrial robot was used to remove the most radioactive elements and dispose of most of the magnesium containing aggregates present. In a very stringent working environment with high chemical risk, Salvarem is also helping to dismantle the chemical purification laboratory at Cadarache.

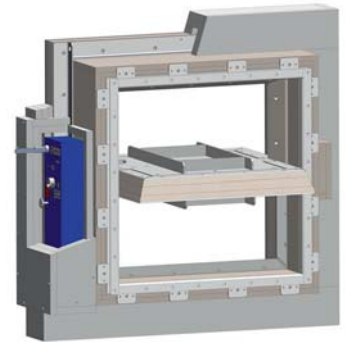

CADARACHE CENTRE (FRANCE)

Vraco protects a reactor from smoke risk

The DCNS awarded a contract to Vraco to design, qualify and supply smoke dampers for the experimental Jules Horowitz reactor (RJH) at the French atomic energy agency's Cadarache site. The reactor is designed to carry out research on the behaviour of fuel and materials used in nuclear power stations. The order confirms Vraco's position in fire protection equipment for nuclear ventilation systems.



NUVIA LIMITED

Nuvia Limited continued to expand its operations, including the SDP (Silos Direct Encapsulation Plant) project and the design of Magnox power plant waste storage facilities. At Trawsfynydd, Nuvia decommissioned a legacy storage tank. Nuvia took part in the international ITER programme and managed the Kozloduy power plant decommissioning programme for the EBRD. Nuvia continues to expand from the United Kingdom to India, Sweden and Canada.

TRAWSFYNYDD SITE (UNITED KINGDOM)

An innovative containment

Nuvia Limited played a key role in the major RB tank decontamination and decommissioning project at the Trawsfynydd site in Wales. To safely perform the work on a structure where radioactive contamination was at a high level, the teams used the ModuCon® modular containment system made up of a glass fibre panel structure mounted in a steel frame. The innovative approach to installing the modular containment was specifically developed for the project to cope with the very difficult working environment due to the presence of non-load-bearing floors and limited access around the tank.



ITER PROJECT CADARACHE CENTRE (FRANCE)

Nuvia Canada and Nuvia Limited prepare tritium storage

Throughout 2013, Nuvia Canada and Nuvia Limited continued to work collaboratively. In Canada, the British teams are supporting their Canadian counterparts to design an effluent plant. In France, Nuvia Canada is supporting Nuvia Limited in the development of storage capacity for the main source of energy in the future reactor, tritium, as part of the international ITER programme.

KOZLODUY POWER PLANT (BULGARIA)

Four reactors to be dismantled

In 2013, Nuvia Limited won a high-profile contract to manage dismantling operations for reactors 1 to 4 at the Kozloduy power plant in Bulgaria. Shut down in the 1990s, these reactors are to be dismantled under a major programme funded by the European Bank for Reconstruction and Development (EBRD). Nuvia Limited, working with its Czech sister company Envinet, set up a dedicated team to oversee the entire supply and dismantling programme. The project scope also involves construction of a system to dispose of the waste adjacent to the power plant.

SELLAFIELD SITE (UNITED KINGDOM)

A new life for a historic plant

The Magnox Fuel Storage Pond at Sellafield is a key part of the UK's civil nuclear legacy and one of the country's highest nuclear decommissioning priorities. Nuvia Limited has been awarded the contract to reconfigure the facility's heavily shielded fuel handling cells. These cells were once used to enable the transfer of spent nuclear fuel from reactor transport flasks into storage skips within the pond. Completion of Nuvia's scope of work will enable the cells handling process to be reversed to enable fuel to be recovered from the plant for the first time in nearly thirty years.



SWEDEN AND THE UNITED KINGDOM

Strong growth of radiation protection

The provision of radiological monitoring capabilities form a key part of the Nuvia Group's offer to clients, allowing the safe delivery of operations across all areas of the nuclear industry. Nuvia Nordic currently provides approximately 40% of the Swedish market demand, providing services to enable routine maintenance and servicing of reactors during outages at a number of sites. In the UK, Nuvia's activity in this field increased in 2013, notably as a result of decommissioning operations at a number of Magnox Reactor sites.



ENVINET

Envinet continued to expand its activities in the Czech Republic and beyond. As the country's only company authorised to carry out nuclear measurements, it has performed a large number of waste characterisation assignments. Projects include: ongoing work with King Abdulaziz City for Science and Technology in Saudi Arabia (development of a radiation control system, training), introduction of gamma spectroscopy systems for Russian and Ukrainian power plants, delivery of research projects (UJV Rez, Susen project at the Rez research centre).

LATVIA

Radioactivity under close watch

On the strength of its track record in designing and installing the national rapid alert system in the Czech Republic and then providing long-term support, Envinet won the contract awarded by Latvia to upgrade the country's national radioactivity surveillance and alert system.

The system automatically determines the gamma dose rate, identifies radionuclides, the level of radioactivity in aerosols and the level of radioactive pollution in the Daugava River (the country's leading source of drinking water). It is also capable of measuring radioactive pollution throughout the country in the event of a nuclear accident. The project included the supply of

large amounts of equipment (24 fixed spectroscopic monitoring stations, a mobile spectroscopic station, an aerosol surveillance station, two water monitoring stations and customised data transmission and processing software).





SOLETANCHE FREYSSINET

133 boulevard National
92500 Rueil-Malmaison - France

From August 2014

280 avenue Napoléon Bonaparte
92500 Rueil-Malmaison - France

www.soletanchefreyssinet.com

Director of publication: Jérôme Stubler **Editor in Chief:** Marine d'Anterroches **Design and production:**  **Editorial committee:** Agnès Baranger, Guillaume Billaroch, Stéphane Cognon, Juliette Dumoulin, Isabelle Mennesson, Stéphane Monleau, Jennie Osborne **Contributor:** Antoine Masson

Cover photo: Detailed view of the facade of the MuCEM, the Museum of European and Mediterranean Civilisations in Marseille, France, ©Lisa Ricciotti

Photos: Atkins, Luc Benevello, Marcus Brierley, Plain Communication, Forth Crossing Bridge Constructors Joint Venture, Cédric Helsly, Jean-Marie Huron, Lisa Ricciotti, Soletanche Bachy, Menard, Terre Armée, Freyssinet, Nuvia photo libraries, all rights reserved **Printed** on Condat Silk from sustainably managed forests.

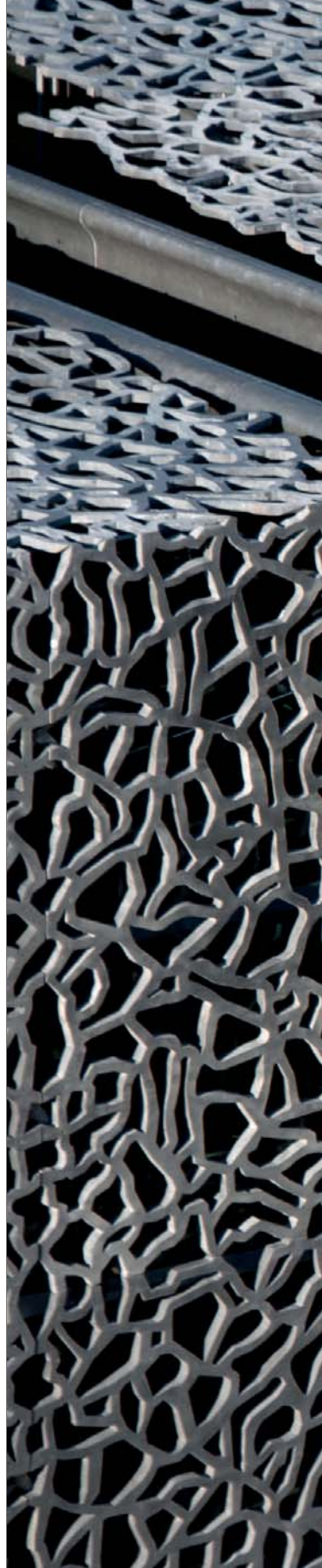

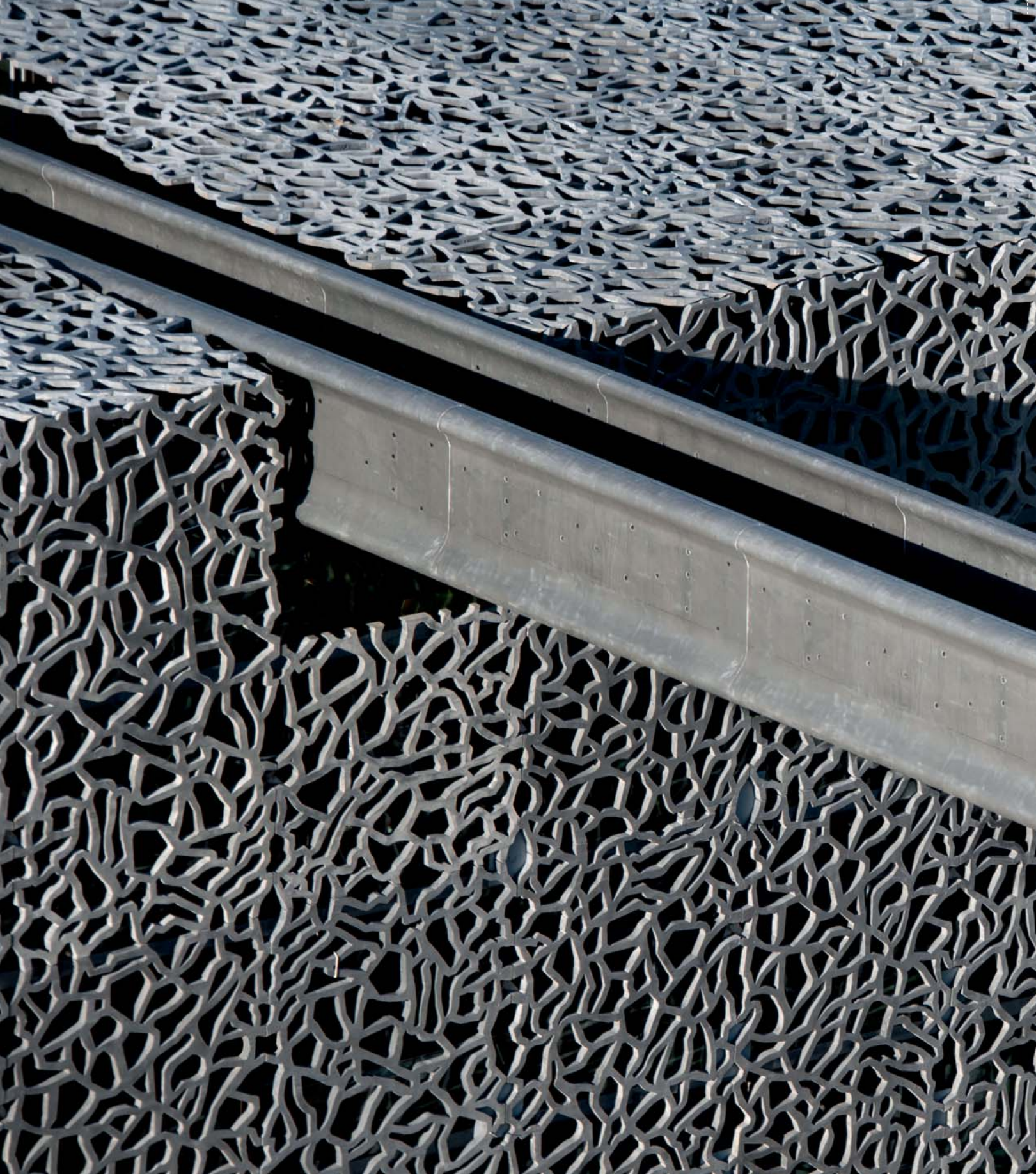

SOLETANCHE BACHY



MENARD



TERRE ARMEE



FREYSSINET



NUVIA